

Posted with permission of the American Academy of Optometry:  
S. Christianson and H. W. Hofstetter,  
"Some Historical Notes on Carl Pulfrich",  
American Journal of Optometry and Archives of the American Academy of Optometry,  
vol. 49, pages 944 - 947.  
Copyright (c) The American Academy of Optometry  
1972

## SOME HISTORICAL NOTES ON CARL PULFRICH\*

Susan Christianson† and H. W. Hofstetter‡  
Division of Optometry, Indiana University  
Bloomington, Indiana

### ABSTRACT

Though Carl Pulfrich (1858-1927) is best known to visual scientists for the stereophenomenon which carries his name, his loss of vision in one eye prevented him from observing the phenomenon. His demonstration apparatus did not include a pendulum as is usually stated in descriptions of the Pulfrich effect. Pulfrich himself gave full credit to others for discovering the phenomenon and for the theoretical explanation. The notion that the effect could be applied to heterochromatic photometry was his own, however.

A few biographical notes of pertinent interest are included.

To English-speaking visual scientists Dr. Carl Pulfrich (1858-1927) is known principally for the stereophenomenon or effect which carries his name. Not realized by many is that throughout the first quarter of this century he was acknowledged as the outstanding authority on stereoscopy and stereoscopic instrument design. Though he published many papers, only one seems to have appeared in English, this being the very comprehensive account under the entry "Stereoscope" in the 11th (1911) edition of Encyclopaedia Britannica. This may still stand as the classic treatment of the topic in the English language, frequently cited as a reference without identification of the author. An editorial footnote to the encyclopaedia article calls attention to the fact that Pulfrich had previously lost the vision of one eye in an accident.

The stereophenomenon bearing Pulfrich's name was originally described in analytical detail in 1922 in a serialized article<sup>1</sup> on the use of the stereoscope for isochromatic and heterochromatic photometry. On page 555 of this series Pulfrich commented (translated), "I have never been able to observe these effects

\*Submitted April 4, 1972, for publication in the November, 1972 issue of the AMERICAN JOURNAL OF OPTOMETRY AND ARCHIVES OF AMERICAN ACADEMY OF OPTOMETRY.

†Secretary and Translator, M.A.

‡Optometrist, Ph.D., Fellow, American Academy of Optometry.

myself, for I have been blind in the left eye for 16 years as a result of a traumatic (blutigen) injury of the eye suffered when I was young." Inasmuch as his paper was delivered in 1921 the blindness would seem to have occurred in 1905. His colleague M.v. Rohr<sup>2</sup> reported the loss of vision due to a cataract. As Pulfrich was 47 years old in 1905, it is not clear how he could have attributed the cataract to an injury sustained when he was young. In his numerous papers on stereoscopy prior to 1905 he did not mention any personal stereoscopic limitations. In a paper<sup>3</sup> published in 1908 he referred to the fact that he personally participated in stereophotogrammetric measurements in a 14 day study in 1904. Hence it may be presumed that his cataract developed quite rapidly during the subsequent year.

In his 1922 description of the now-called Pulfrich effect Pulfrich<sup>1</sup> pointed out that the phenomenon was brought to his attention only two years earlier by Professor Max Wolf of Königstuhl in Heidelberg in his 1920 "Veröffentlichungen der Badischen Sternwarte zu Heidelberg, Bd. 7, Nr. 10, S.29." In this publication, according to Pulfrich, Wolf described a noteworthy stereo-effect which now and then disturbingly confronted him during rapid movements of a pair of plates in the stereocomparator. Pulfrich also pointed out that he later learned that the same phenomenon had been observed even earlier by other users of the "Stereo-Autographen," naming v. Orel, E. Wolf Lembergen, Tiller, v. Gruber u.a.

Because the phenomenon would be interpreted all too easily as a flaw in the Zeiss-made stereo apparatus, the officials of the Zeiss firm assigned the problem to an engineer named Franke and a technical assistant (Studienassessor) named F. Fertsch. To the latter Pulfrich gave full credit for finding that it was the difference in brightness of the views in front of the two eyes that elicited the effect. He also credited Fertsch with the explanation of the phenomenon in terms

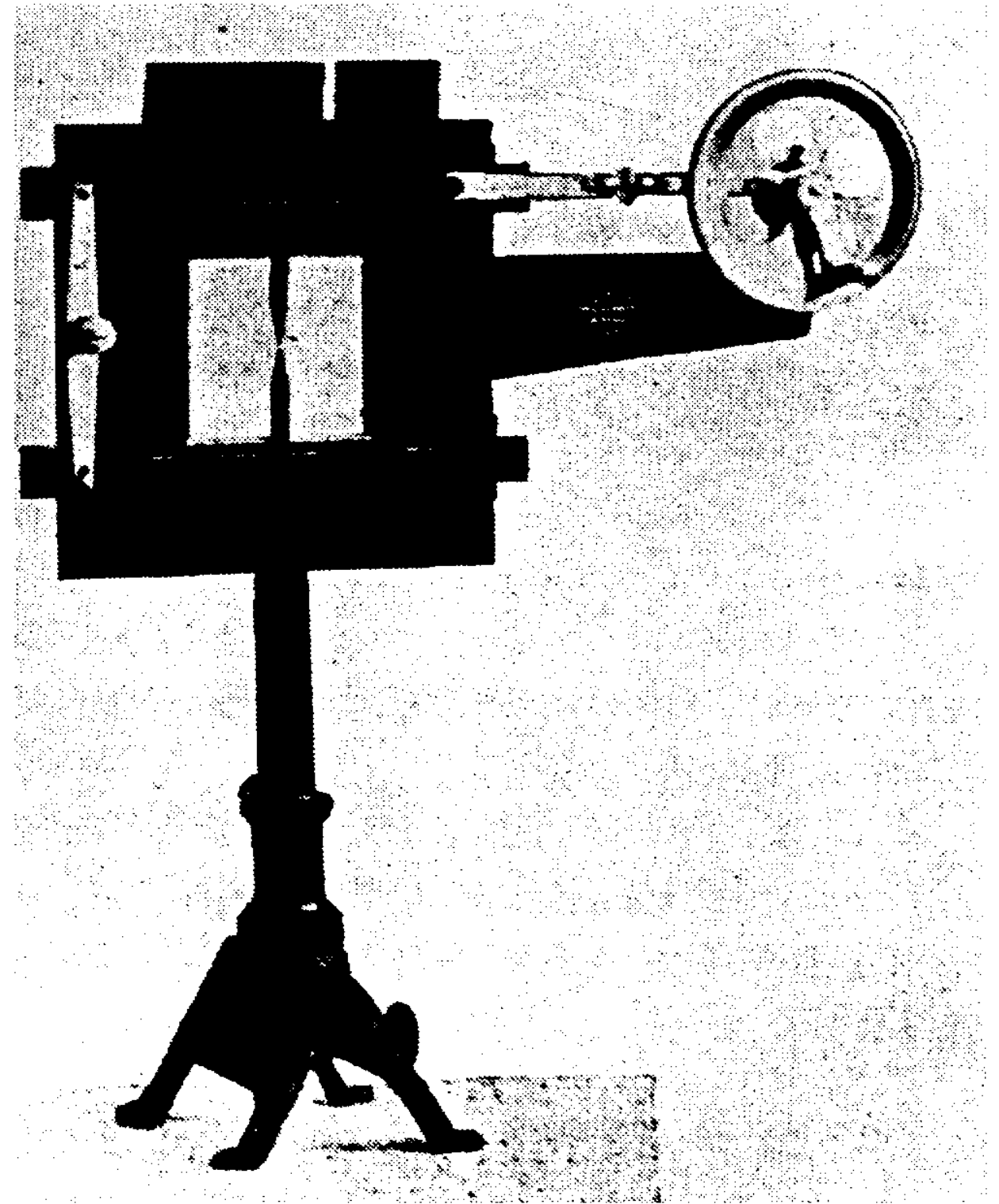
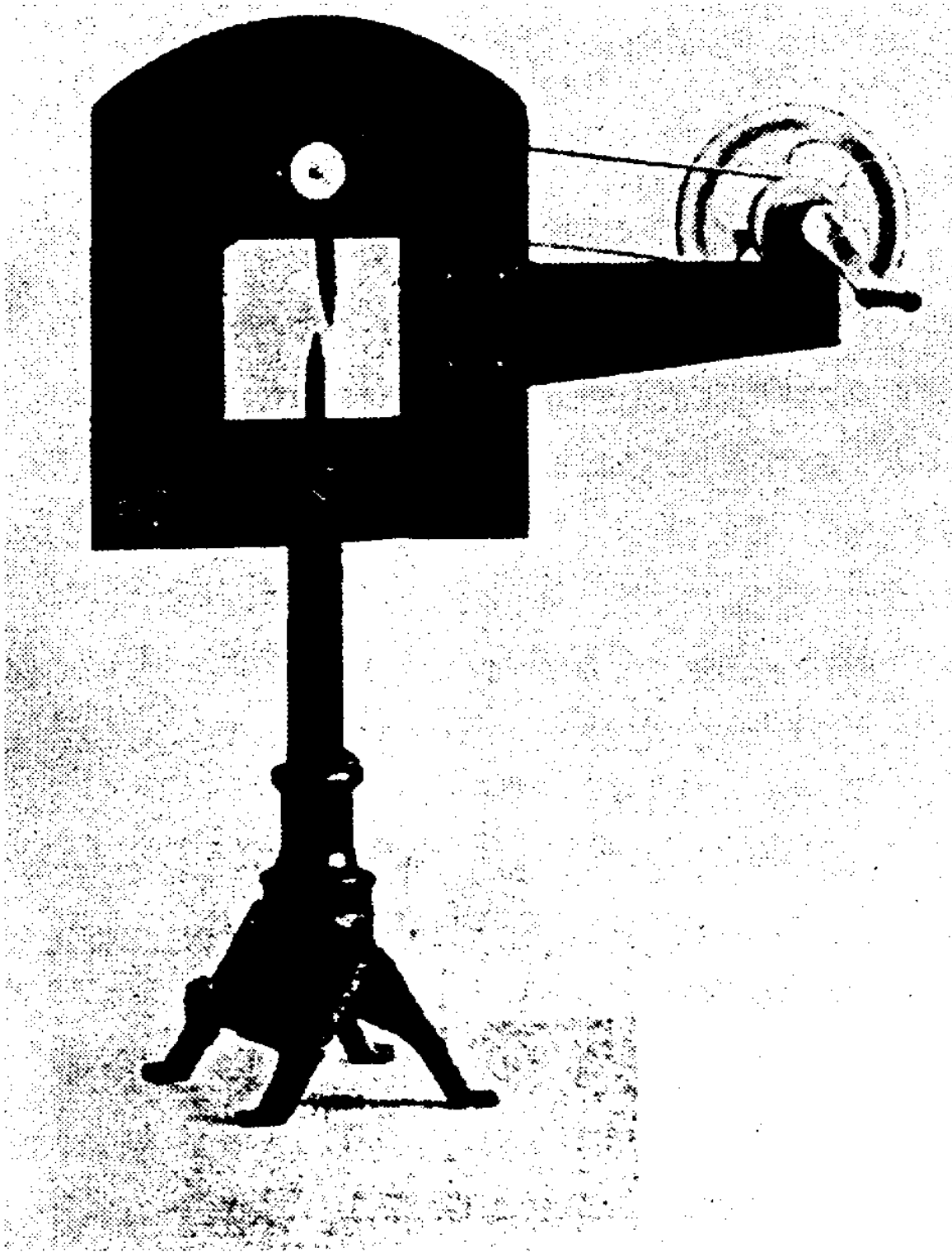

Fig. 1. (Left) Pulfrich's original demonstration apparatus.  
Fig. 2. (Right) Pulfrich's second demonstration model.

of a difference in perceptual latency. For the theoretical analysis of the path of apparent movement based on an assumed perceptual latency Pulfrich gave credit to his son Hans, a Doctor of Philosophy. Pulfrich credited himself, however, with the notion that the phenomenon could be useful in heterochromatic photometry.

To demonstrate the effect in a dramatic way Pulfrich designed first a simple apparatus with a large square aperture which, from the published illustration, Fig. 1, appears to have been about 10 x 10 cm. Directly behind the aperture was a fixed vertical pointer which was seen projecting upward from the center of the base of the aperture almost to the center of the aperture. Mounted on an axis directly above and behind the aperture was a series of six similarly shaped pointers, each of which, when centered in the aperture, was directly above, pointing downward, and in vertical alignment with the lower pointer. By means of a pair of belt pulleys, one of which was attached to the upper pointers as spokes on a wheel, and the other pulley serving as a hand crank, the upper, downward extending, pointers could be made to glide past the aperture, to be judged in front of or behind the plane of the lower fixed pointer according to the effect induced by a filter in front of one eye of an observer.

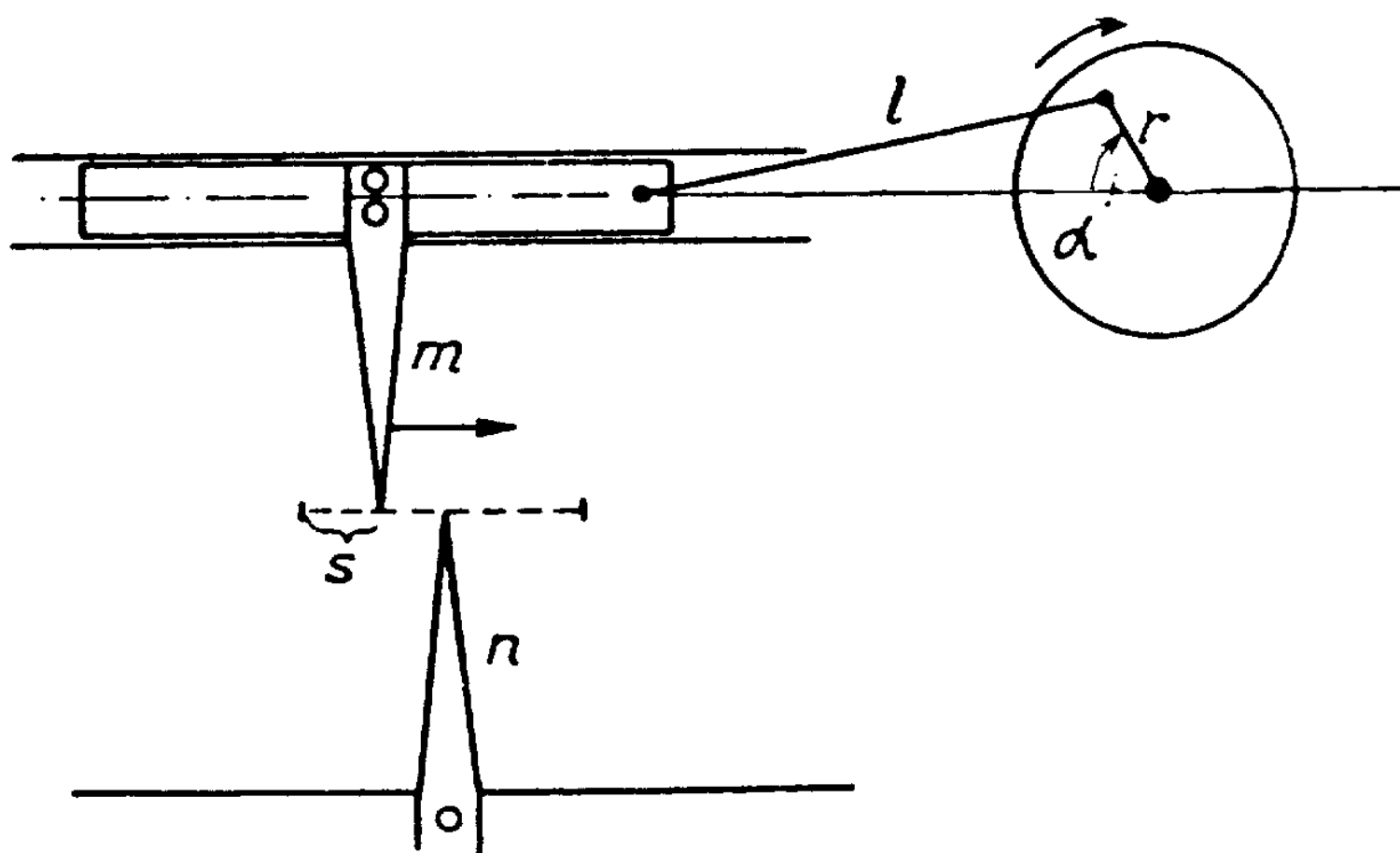

Fig. 3. Mechanism of Pulfrich's second model.

Contrary to the usual description of the Pulfrich effect in terms of the apparent path of a pendulum, this apparatus was neither a pendulum nor was the speed of its laterally moving pointer that of simple harmonic motion.

In his second demonstration model, Figs 2 and 3, Pulfrich mounted the upper pointer on a laterally moving reciprocating shaft activated by linkage to an eccentrically located pin on a rotating drive wheel. Hence, it also was not a pendulum, though closely approximating pendulum movement in its simple harmonic motion.

Born September 24, 1858, in Düsseldorf, Germany, Carl Pulfrich attended the Realgymnasium in Mühlheim a.d. Ruhr and studied physics, mathematics, and mineralogy at the University of Bonn. He was awarded the Ph.D. degree in 1881. Following a short period of military service, teaching, and research, he joined the scientific staff of the Zeiss firm in Jena, Germany, in 1890 where he remained until his death. His publications suggest three major phases in his career: refractometry from 1885 to 1899, stereoscopy from 1899 to 1920, and photometry from 1920 to 1927. His work in photometry, however, related

almost entirely to the utilization of the stereophenomenon which bears his name, so it may be stated quite fairly that he devoted more than a quarter of a century to research and development in stereoscopy.

His death, on August 12, 1927, was caused by drowning in the Baltic Sea when his canoe capsized.

#### REFERENCES

1. Pulfrich, C., Die Stereoskopie im Dienste der isochromen und heterochromen Photometrie, Die Naturwissenschaften, 10 (25, 26, 27, 33, 34, and 35) : June 23, 30, July 7, August 18, 25, and September 1, 1922, pp. 553-564, 569-574, 596-601, 714-722, 735-743, and 751-761. (Incomplete translations available at the Indiana University Optometry Library. Bloomington, Indiana 47401).
2. Rohr, M.v., Carl Pulfrich, Central-Zeitung für Optik und Mechanik/Electrotechnik und verwandte Berutzweige 48 (19) : 243-244, 1927.
3. Pulfrich, C., Ueber die Ausmessung stereophotogrammetrischer Küstenaufnahmen vom Schiff aus, Zeitschrift für Instrumentenkunde, 28 (11) : 317-326, 1908.